



RCF



Closed circuit cooling towers

Engineering data

REMARK: Do not use for construction. Refer to factory certified dimensions & weights. This page includes data current at time of publication, which should be reconfirmed at the time of purchase. In the interest of product improvement, specifications, weights and dimensions are subject to change without notice.

Last update: 12 April 2016

Dimensions showing location of refrigerant connections are approximate and should not be used for prefabrication of connecting piping.

2. Refrigerant inlet and outlet connections are beveled for welding. standard size for inlet and outlet connections is 100NB.

3. Maximum drain size is based on a bottom connection.

4. Standard make-up, drain and overflow connections are MPT.

5. Unit height is indicative, for precise value please refer to certified print.

6. Operating weight is for the unit with the water level at the overflow.

7. Dimensions, shipping and operating weights indicated are for units without accessories. Consult your local BAC representative for further information.

RCF 0505-0707

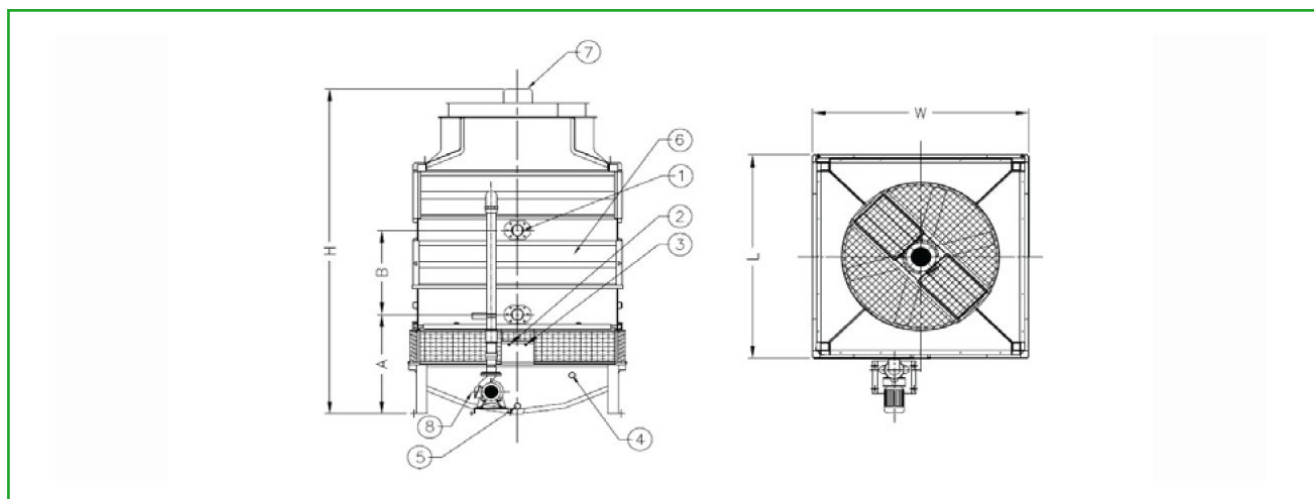

1. Coil inlet and outlet connections; 2. Make-up; 3. Quick fill; 4. Overflow; 5. Drain; 6. Access door; 7. Fan motor; 8. Recirculation spray pump.

RCF 0710-1116

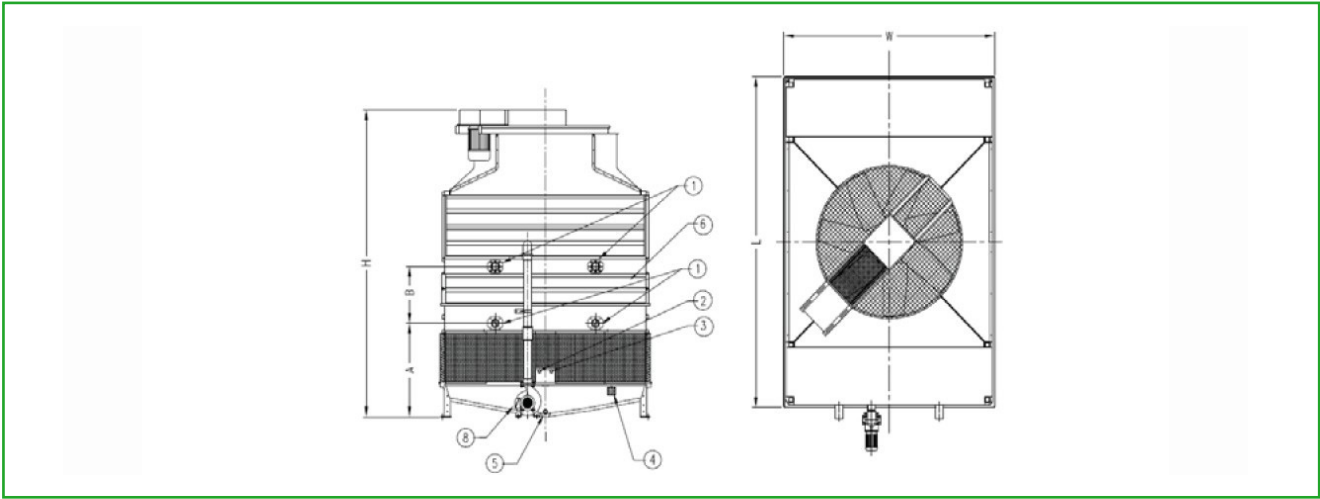

RCF 0808-1111

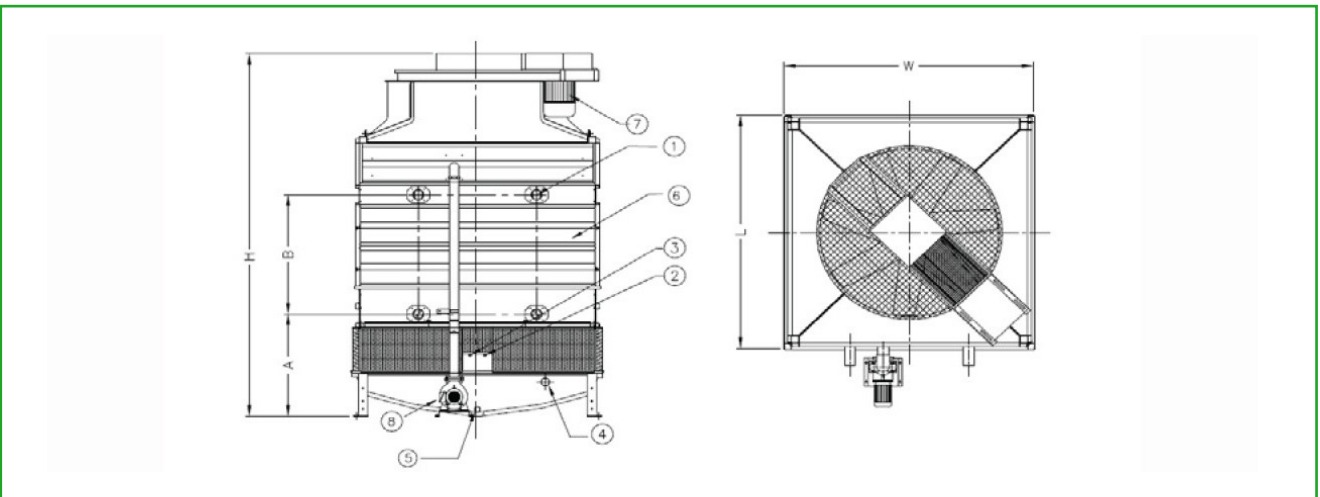

1. Coil inlet and outlet connections; 2. Make-up; 3. Quick fill; 4. Overflow; 5. Drain; 6. Access door; 7. Fan motor; 8. Recirculation spray pump.

Model	Weights (kg)			Dimensions (mm)			Airflow (m ³ /s)	Fan Motor (kW)	Water Flow (l/s)	Pump Motor (kW)	Coil volume (l)
	Oper. Weight (kg)	Ship. Weight (kg)	Heaviest Section (kg)	L (mm)	W (mm)	H (mm)					
RCF 0505-0-G	1900	1020	690	12270	1674	2600	7.42	(1x) 2.2kW	(1x) 6.8	(1x) 0.55 kW	(1x) 118
RCF 0505-0-I	1900	1020	690	12270	1674	2600	8.07	(1x) 4.0kW	(1x) 6.8	(1x) 0.55 kW	(1x) 118
RCF 0505-1-G	2100	1210	880	12270	1674	2900	6.92	(1x) 2.2kW	(1x) 6.8	(1x) 0.55 kW	(1x) 180
RCF 0505-2-G	2300	1380	1050	12270	1674	3010	6.5	(1x) 2.2kW	(1x) 6.8	(1x) 0.55 kW	(1x) 242



Model	Weights (kg)			Dimensions (mm)			Airflow (m ³ /s)	Fan Motor (kW)	Water Flow (l/s)	Pump Motor (kW)	Coil volume (l)
	Oper. Weight (kg)	Ship. Weight (kg)	Heaviest Section (kg)	L (mm)	W (mm)	H (mm)					
RCF 0505-2-I	2300	1380	1050	12270	1674	3010	7.86	(1x) 4.0kW	(1x) 6.8	(1x) 0.55 kW	(1x) 242
RCF 0505-3-I	2550	1560	1230	12270	1674	3315	7.5	(1x) 4.0kW	(1x) 6.8	(1x) 0.55 kW	(1x) 304
RCF 0505-3-J	2550	1560	1230	12270	1674	3315	8.11	(1x) 5.5kW	(1x) 6.8	(1x) 0.55 kW	(1x) 304
RCF 0606-2-I	3150	1830	1550	21977	1979	3280	9.95	(1x) 4.0kW	(1x) 9.8	(1x) 0.75 kW	(1x) 349
RCF 0606-2-J	3150	1830	1550	21977	1979	3280	11.1	(1x) 5.5kW	(1x) 9.8	(1x) 0.75 kW	(1x) 349
RCF 0606-3-I	3500	2080	1800	21977	1979	3585	9.54	(1x) 4.0kW	(1x) 9.8	(1x) 0.75 kW	(1x) 439
RCF 0606-3-J	3500	2080	1800	21977	1979	3585	11.0	(1x) 5.5kW	(1x) 9.8	(1x) 0.75 kW	(1x) 439
RCF 0606-3-K	3500	2080	1800	21977	1979	3585	11.6	(1x) 7.5kW	(1x) 9.8	(1x) 0.75 kW	(1x) 439
RCF 0707-2-I	4100	2390	2050	22282	2284	3470	12.4	(1x) 4.0kW	(1x) 13.3	(1x) 0.75 kW	(2x) 469
RCF 0707-2-J	4100	2390	2050	22282	2284	3470	13.6	(1x) 5.5kW	(1x) 13.3	(1x) 0.75 kW	(2x) 469
RCF 0707-2-K	4100	2390	2050	22282	2284	3470	13.6	(1x) 7.5kW	(1x) 13.3	(1x) 0.75 kW	(2x) 469
RCF 0707-3-J	4600	2730	2390	22282	2284	3775	13.1	(1x) 5.5kW	(1x) 13.3	(1x) 0.75 kW	(2x) 588
RCF 0707-3-K	4600	2730	2390	22282	2284	3775	14.7	(1x) 7.5kW	(1x) 13.3	(1x) 0.75 kW	(2x) 588
RCF 0710-2-J	6150	3580	3070	23418	2284	4125	18.1	(1x) 5.5kW	(1x) 20.4	(1x) 1.5 kW	(2x) 744
RCF 0710-2-K	6150	3580	3070	23418	2284	4125	19.8	(1x) 7.5kW	(1x) 20.4	(1x) 1.5 kW	(2x) 744
RCF 0710-2-L	6150	3580	3070	23418	2284	4125	22.5	(1x) 11.0kW	(1x) 20.4	(1x) 1.5 kW	(2x) 744
RCF 0710-3-L	6850	4090	3580	23418	2284	4535	21.5	(1x) 11.0kW	(1x) 20.4	(1x) 1.5 kW	(2x) 912
RCF 0710-3-M	6850	4090	3580	23418	2284	4535	23.9	(1x) 15.0kW	(1x) 20.4	(1x) 1.5 kW	(2x) 912
RCF 0808-2-K	5250	3050	2790	22586	2588	3450	18.7	(1x) 7.5kW	(1x) 17.4	(1x) 0.75 kW	(2x) 624
RCF 0808-2-L	5250	3050	2790	22586	2588	3450	20.5	(1x) 11.0kW	(1x) 17.4	(1x) 0.75 kW	(2x) 624
RCF 0808-3-K	5850	3500	3230	22586	2588	3755	17.6	(1x) 7.5kW	(1x) 17.4	(1x) 0.75 kW	(2x) 624
RCF 0808-3-L	5850	3500	3230	22586	2588	3755	20.1	(1x) 11.0kW	(1x) 17.4	(1x) 0.75 kW	(2x) 624
RCF 0812-2-L	7850	4560	4180	23874	2588	4145	26.6	(1x) 11.0kW	(1x) 26.5	(1x) 2.2 kW	(2x) 1176



Model	Weights (kg)			Dimensions (mm)			Airflow (m ³ /s)	Fan Motor (kW)	Water Flow (l/s)	Pump Motor (kW)	Coil volume (l)
	Oper. Weight (kg)	Ship. Weight (kg)	Heaviest Section (kg)	L (mm)	W (mm)	H (mm)					
RCF 0812-2-M	7850	4560	4850	23874	2588	4145	29.4	(1x) 15.0kW	(1x) 26.5	(1x) 2.2 kW	(2x) 984
RCF 0812-3-L	8750	5230	4850	23874	2588	4465	28.4	(1x) 11.0kW	(1x) 26.5	(1x) 2.2 kW	(2x) 1176
RCF 0812-3-M	8750	5230	4850	23874	2588	4465	28.4	(1x) 15.0kW	(1x) 26.5	(1x) 2.2 kW	(2x) 1176
RCF 0812-3-N	8750	5230	4180	23874	2588	4465	30.4	(1x) 18.5kW	(1x) 26.5	(1x) 2.2 kW	(2x) 1176
RCF 0909-2-K	6450	3810	4060	22891	2893	3580	21.6	(1x) 7.5kW	(1x) 22.0	(1x) 1.1 kW	(2x) 801
RCF 0909-2-L	6450	3810	4060	22891	2893	3580	24.3	(1x) 11.0kW	(1x) 22.0	(1x) 1.1 kW	(2x) 801
RCF 0909-3-L	7200	4380	3500	22891	2893	3885	23.3	(1x) 11.0kW	(1x) 22.0	(1x) 1.1 kW	(2x) 1001
RCF 0909-3-M	7200	4380	3500	22891	2893	3885	23.3	(1x) 15.0kW	(1x) 22.0	(1x) 1.1 kW	(2x) 1001
RCF 0913-2-M	9650	5710	4250	24328	2893	4205	32.0	(1x) 15.0kW	(1x) 33.5	(1x) 2.2 kW	(2x) 1249
RCF 0913-2-N	9650	5710	4250	24328	2893	4205	35.0	(1x) 18.5kW	(1x) 33.5	(1x) 2.2 kW	(2x) 1249
RCF 0913-3-M	10800	6560	6090	24328	2893	4525	33.8	(1x) 15.0kW	(1x) 33.5	(1x) 2.2 kW	(2x) 1538
RCF 0913-3-N	10800	6560	6090	24328	2893	4525	36.0	(1x) 18.5kW	(1x) 33.5	(1x) 2.2 kW	(2x) 1538
RCF 0913-3-O	10800	6560	6090	24328	2893	4525	38.3	(1x) 22.0kW	(1x) 33.5	(1x) 2.2 kW	(2x) 1538
RCF 1010-2-L	7750	4580	4210	23198	3200	3820	28.3	(1x) 11.0kW	(1x) 27.1	(1x) 2.2 kW	(2x) 1020
RCF 1010-2-M	7750	4580	4910	23198	3200	3820	30.9	(1x) 15.0kW	(1x) 27.1	(1x) 2.2 kW	(2x) 1020
RCF 1010-3-L	8700	5280	4210	23198	3200	4125	27.3	(1x) 11.0kW	(1x) 27.1	(1x) 2.2 kW	(2x) 1248
RCF 1010-3-M	8700	5280	4910	23198	3200	4125	29.8	(1x) 15.0kW	(1x) 27.1	(1x) 2.2 kW	(2x) 1248
RCF 1010-3-N	8700	5280	4910	23198	3200	4125	31.9	(1x) 18.5kW	(1x) 27.1	(1x) 2.2 kW	(2x) 1248
RCF 1015-2-N	11600	6870	6310	24785	3200	4400	39.3	(1x) 18.5kW	(1x) 41.3	(1x) 3.0 kW	(2x) 1488
RCF 1015-2-O	11600	6870	6310	24785	3200	4400	41.4	(1x) 22.0kW	(1x) 41.3	(1x) 3.0 kW	(2x) 1488
RCF 1015-3-N	13000	7920	7360	24785	3200	4720	40.3	(1x) 18.5kW	(1x) 41.3	(1x) 3.0 kW	(2x) 1916
RCF 1015-3-O	13000	7920	7920	24785	3200	4720	42.5	(1x) 22.0kW	(1x) 41.3	(1x) 3.0 kW	(2x) 1916
RCF 1015-3-P	13000	7920	7360	24785	3200	4720	47.2	(1x) 30.0kW	(1x) 41.3	(1x) 3.0 kW	(2x) 1916



Model	Weights (kg)			Dimensions (mm)			Airflow (m ³ /s)	Fan Motor (kW)	Water Flow (l/s)	Pump Motor (kW)	Coil volume (l)
	Oper. Weight (kg)	Ship. Weight (kg)	Heaviest Section (kg)	L (mm)	W (mm)	H (mm)					
RCF 1111-2-M	9150	5450	5040	23498	3500	3985	35.7	(1x) 15.0kW	(1x) 32.8	(1x) 2.2 kW	(2x) 1191
RCF 1111-2-N	9150	5450	5040	23498	3500	3985	32.7	(1x) 18.5kW	(1x) 32.8	(1x) 2.2 kW	(2x) 1191
RCF 1111-3-M	10300	6300	5880	23498	3500	4290	33.5	(1x) 15.0kW	(1x) 32.8	(1x) 2.2 kW	(2x) 1493
RCF 1111-3-N	10300	6300	5880	23498	3500	4290	36.1	(1x) 18.5kW	(1x) 32.8	(1x) 2.2 kW	(2x) 1493
RCF 1111-3-O	10300	6300	5880	23498	3500	4290	37.1	(1x) 22.0kW	(1x) 32.8	(1x) 2.2 kW	(2x) 1493
RCF 1116-2-O	13700	8180	7560	25245	3500	4585	50.9	(1x) 22.0kW	(1x) 49.9	(1x) 4.0 kW	(2x) 1826
RCF 1116-2-P	13700	8180	7560	25245	3500	4585	57.9	(1x) 30.0kW	(1x) 49.9	(1x) 4.0 kW	(2x) 1826
RCF 1116-3-O	15400	9450	8820	25245	3500	4905	50.0	(1x) 22.0kW	(1x) 49.9	(1x) 4.0 kW	(2x) 2284
RCF 1116-3-P	15400	9450	8820	25245	3500	4905	54.3	(1x) 30.0kW	(1x) 49.9	(1x) 4.0 kW	(2x) 2284