



Minimizing Energy Costs with Free Cooling

Free cooling reduces refrigeration energy consumption by using evaporative cooling equipment to produce chilled water in cool weather. This section provides general guidelines for optimizing the selection and application of free cooling systems.

> Overview

Many air conditioning and industrial cooling systems require chilled water throughout the year. During fall, winter, and spring, a system's cooling tower or closed circuit cooling tower can produce water cool enough to eliminate the need to operate a chiller. This is known as free cooling or evaporative chilling. There are too many variations among buildings and systems for these guidelines to be all inclusive. Therefore, it is important to contact your local BAC Representative to ensure that the system is properly sized and that all guidelines have been followed.

Free cooling can be designed into new chilled water systems or retro-fitted into existing systems. Even in warm climates, this process can produce energy savings. Money is saved by operating a cooling tower fan motor, which consumes about 0.2 kW/ton, rather than a chiller compressor motor, consuming about 0.6 to 0.8 kW/ton.

> Chilled Water Load and Temperatures

An exact load calculation is not necessary to select a free cooling system, but a load estimate is required to closely predict a system's number of hours of operation and its annual energy savings.

For industrial process, computer, and other constant load systems, winter cooling load is known. For air conditioning systems, winter cooling load is always less than summer cooling load and represents mostly internal heat gains, which are fairly constant, although winter solar heat gain can be significant.

Little or no dehumidification is required during cool weather, so water temperatures can be higher than normal, extending the number of hours during which the energy savings benefits of free cooling can be utilized. Typical winter chilled water supply and return temperatures can be as low as 50°F (10°C) and 55°F (12.8°C), respectively, in colder climates. The minimum practical leaving water temperature is 42°F (5.6°C) for cooling towers and 45°F (7.2°C) for closed circuit cooling towers.

Optimizing system water temperature should always be considered when designing a free cooling system. For example, during the summer in the Baltimore area, a 500 nominal ton cooling tower provides 1,500 gpm of water cooled from 95°F (35°C) to 85°F (29.4°C) at a 78°F (25.6°C) entering wet bulb temperature. If the same cooling tower were used for free cooling assuming 60% of the peak load, maintaining a 43°F (6.1°C) leaving water temperature would provide approximately 1,900 hours of free cooling operation. Increasing the leaving water temperature to 50°F (10°C) would increase free cooling operation to 2,900 hours. This process can achieve a 10% energy savings because the chiller can be shut off at the higher temperature. Therefore optimizing system water temperature should be considered when designing a free cooling system.

> Flow Rate, Pumps, and Piping

Condenser water and chilled water pumps represent a significant part of total system energy consumption. At reduced winter loads, it may not be necessary to maintain the design flow rate, and energy can be saved by reducing pump motor speed, operating smaller pumps, or using two-speed pumps. If chilled water piping extends above the level of cooling tower overflow (for example, a tower at grade level) an open system is not practical unless the water can be prevented from draining through the tower at shutdown.

> Size of Cooling Tower

The cooling tower or closed circuit cooling tower required depends on the load, ambient wet-bulb temperature, and leaving water temperature (**Figure 1**). For low leaving water temperatures, the unit size may be larger for winter duty than summer duty, even though the load is reduced during the winter. Operating more cooling tower capacity during winter may be justified to achieve the required chilled water temperature for the longest period of time. Because each ton of cooling tower capacity with energy consumption of about 0.2 kW/ton replaces a ton of chiller capacity with energy consumption of about 0.6 to 0.8 kW/ton, it makes sense to install and operate at the greatest practical free cooling capacity.

If the optimum summer and winter cooling capacities or flows are very different, it would be impractical to operate a single unit for both purposes. Acceptable water loading of cooling towers is limited by nozzle size and water/air ratio, which can vary considerably among manufacturers. If either summer or winter conditions fall outside the limits of a particularly sized unit, separate or multi-cell units are recommended. The sizes may be selected so that both operate during one season and only one operates during another season.

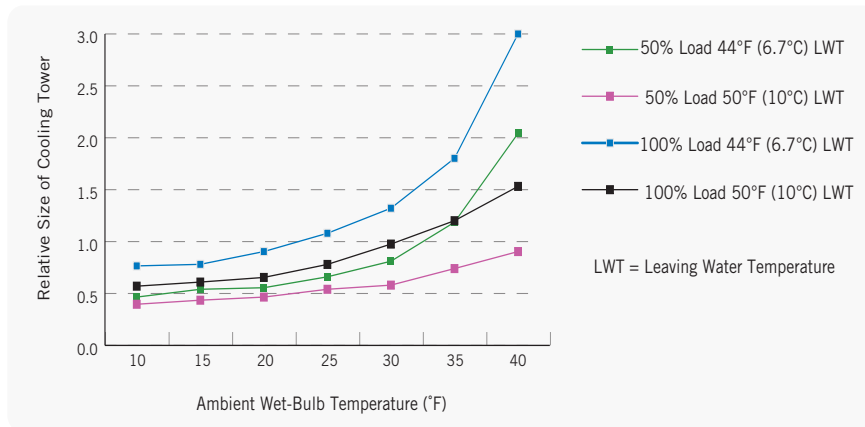

Figure 1. The Required Size of a Cooling Tower or Closed Circuit Cooling Tower Depends on the Load, Ambient Wet-Bulb Temperature, and Leaving Water Temperature

For example, if the peak summer load requires a nominal capacity of 400 tons of cooling, while the winter load requires only 150 tons of cooling, providing a single 400 ton cooling tower is not feasible, because the water loading on the tower will be less than half during winter operation. Decreased flow to the cooling tower may promote scale buildup in the fill because of wet and dry patches, drift, and, especially during the winter, freezing in the fill. Therefore, providing two of the 200 ton towers would be more practical. For the summer load, both 200 ton towers would operate, while during winter, only one would operate.

> Heat Exchangers

The capacity/size and cost of heat exchangers depends on the temperature difference between the two circuits and on allowable pressure drop. The lowest possible temperature difference between circuits—about 5°F (2.8°C) or less—is desired in evaporative chilling systems. The lower the differential temperature, the higher the cost and the larger the heat exchanger.

Minimizing Energy Costs with Free Cooling

> Type of System

The majority of free cooling systems fall into the following three main categories with a few variations:

1. Cooling Tower and Heat Exchanger (Figure 2):

During the summer, the system operates as a conventional cooling tower/chiller system. During the winter, the chiller is bypassed, and the cold water produced by the cooling tower cools the chilled water serving the load through a heat exchanger. Systems of this type have been operated successfully in colder climates and are economical in warmer climates as well.

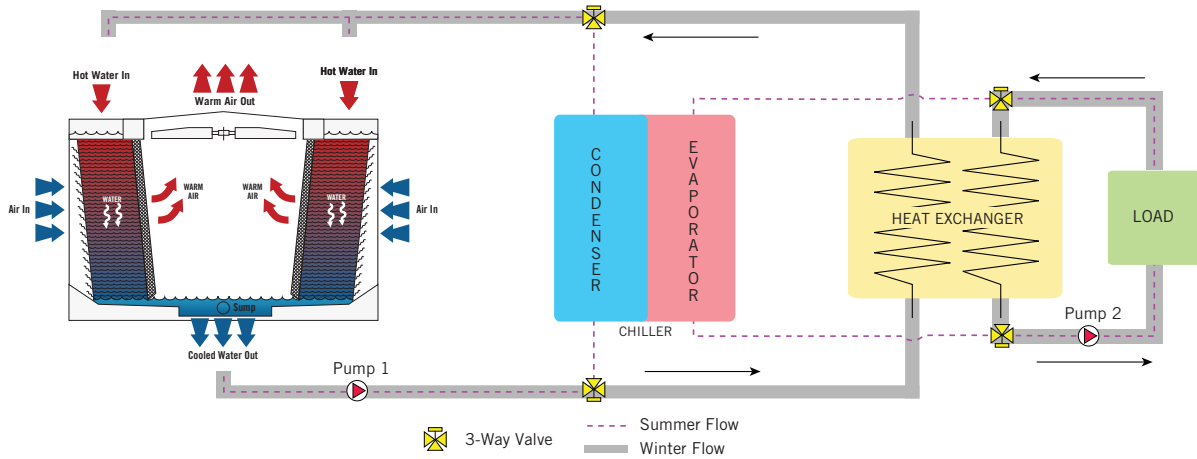

Figure 2. Cooling Tower and Heat Exchanger Free Cooling System

- **Variation 1 - Summer Tower and Winter Tower with a Heat Exchanger System (Figure 2a):** One cooling tower is sized and exclusively used for the condenser load and it is not winterized, so it must be shut down and drained for the winter. A second cooling tower is sized and exclusively used for the free cooling load. This system offers the most flexibility in optimizing the tower and heat exchanger selections.

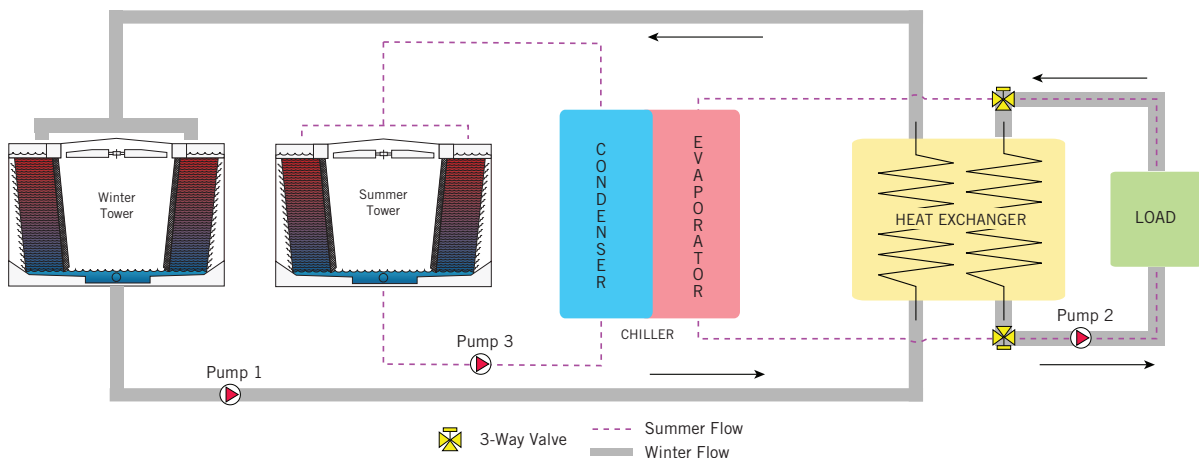

Figure 2a. Variation 1 - Summer and Winter Tower with a Heat Exchanger System

- **Variation 2 - Summer Tower and Winter/Summer Tower with a Heat Exchanger System (Figure 2b):** One cooling tower is sized for the free cooling load but is also used for the condenser load which is greater than the free cooling load. A second cooling tower is sized and exclusively used for the balance of the condenser load, and it is not winterized.

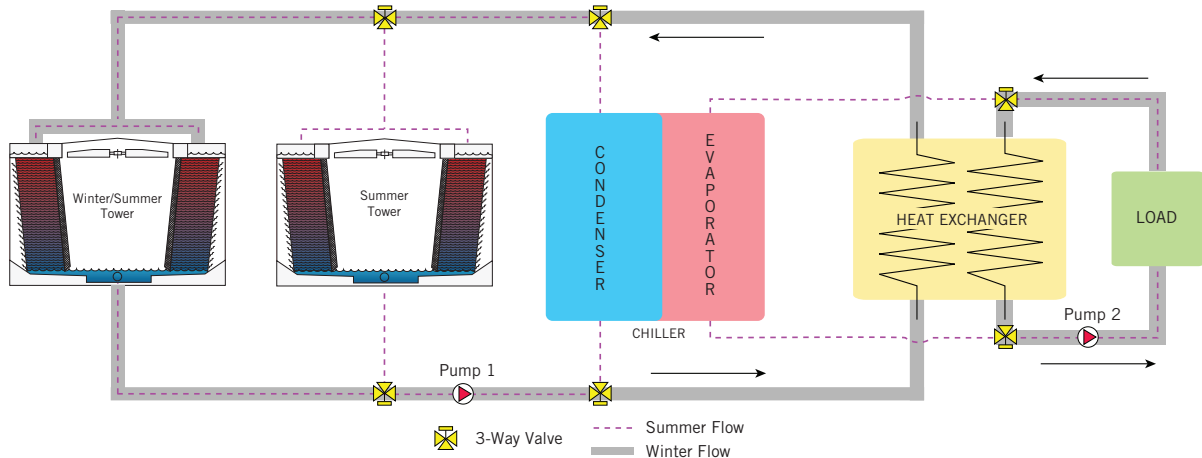

Figure 2b. Variation 2 - Summer and Winter/Summer Tower with a Heat Exchanger System

- **Variation 3 - Summer Tower and Winter Tower with a Heat Exchanger System with Load Shaving (Figure 2c):** The summer cooling tower is sized for the summer condenser load and then used for that summer condenser load and the reduced condenser load when load shaving. The cooling tower and heat exchanger begin to shave the load at a predetermined wet-bulb temperature by handling a portion of the chilled water load. As the wet-bulb temperature drops, the tower and heat exchanger handle an increased share of the load until the compressor finally can be turned off.

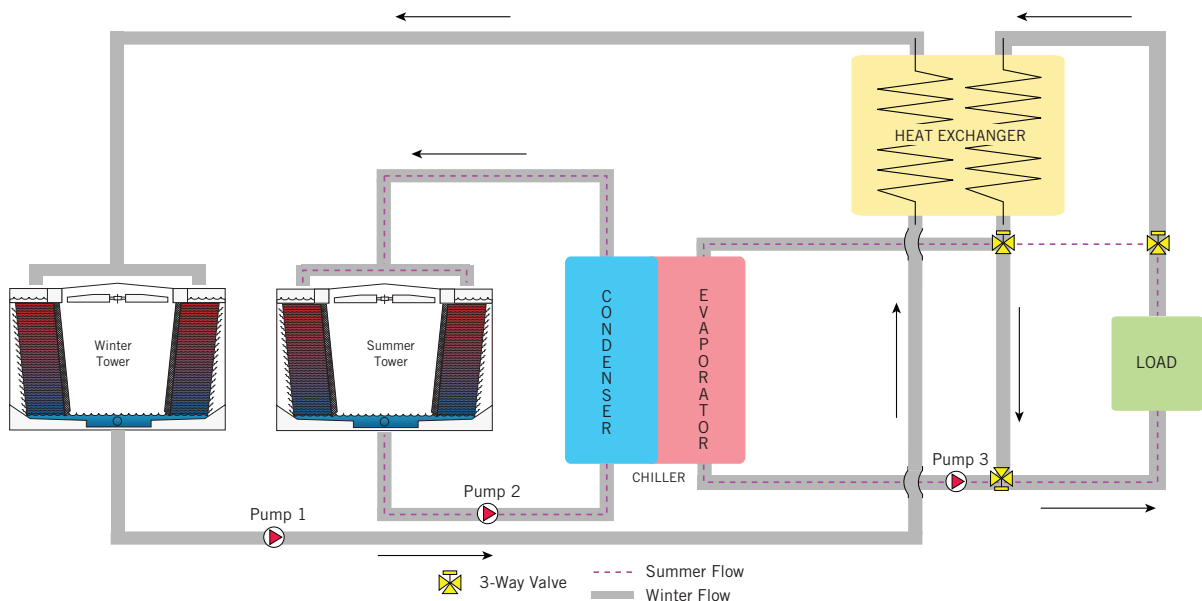

Figure 2c. Variation 3 - Summer and Winter Tower with a Heat Exchanger System with Load Shaving

Minimizing Energy Costs with Free Cooling

2. Closed Circuit Cooling Tower (Figure 3):

In this system, a closed circuit cooling tower replaces the cooling tower and heat exchanger in the condenser water loop. During the summer, water from the tower is circulated in a closed loop through the condenser of the chiller. During the winter, cold water from the tower is circulated in a closed loop directly through the chilled water circuit. This system is the only one combining the operating simplicity of a single circuit with the reliability of a closed, chilled water loop. This type of application is feasible with closed circuit cooling towers because contaminants in the recirculating water are never in direct contact with the system water.

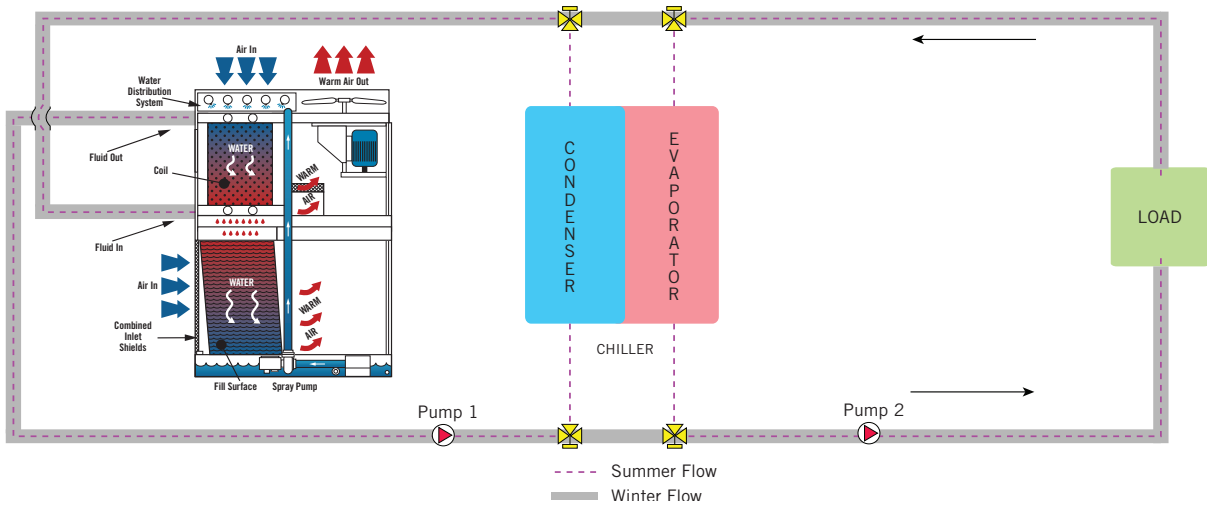

Figure 3. Closed Circuit Cooling Tower Free Cooling System

- **Variation 1 - Closed Circuit Cooling Tower System with a Summer Cooling Tower (Figure 3a):** The closed circuit cooling tower is sized and exclusively used for the free cooling load. An open cooling tower is sized for and exclusively used for the condenser load and is not winterized. This system variation offers the best year round energy savings of the four closed circuit cooling tower variations because the condenser load is handled by an open cooling tower which requires less energy than a closed circuit cooling tower.

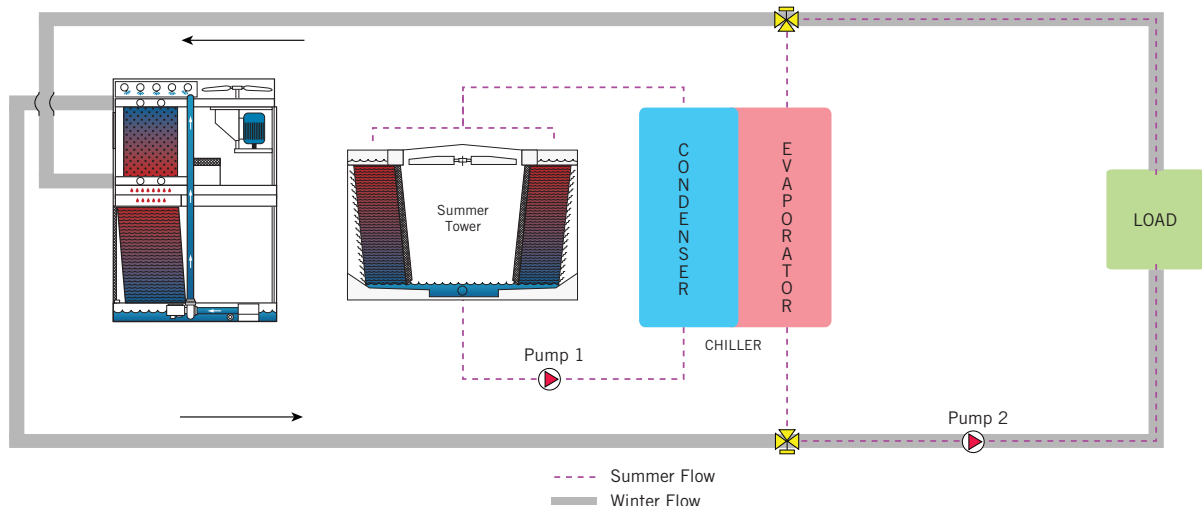

Figure 3a. Variation 1 - Closed Circuit Cooling Tower Free Cooling System with a Summer Cooling Tower

- Variation 2 - Closed Circuit Cooling Tower System with a Summer Cooling Tower for Multiple Chillers (Figure 3b):**
 For systems with multiple chillers, the closed circuit cooling tower is sized for the free cooling load, but also is used for a portion of the total condenser load. An open cooling tower is sized and exclusively used for the balance of the condenser load, and it is not winterized. This system variation offers the flexibility of using the open cooling tower for the condenser load during the majority for the summer with the benefit of low horsepower and lower first cost than the previous two closed circuit cooling tower system variations.

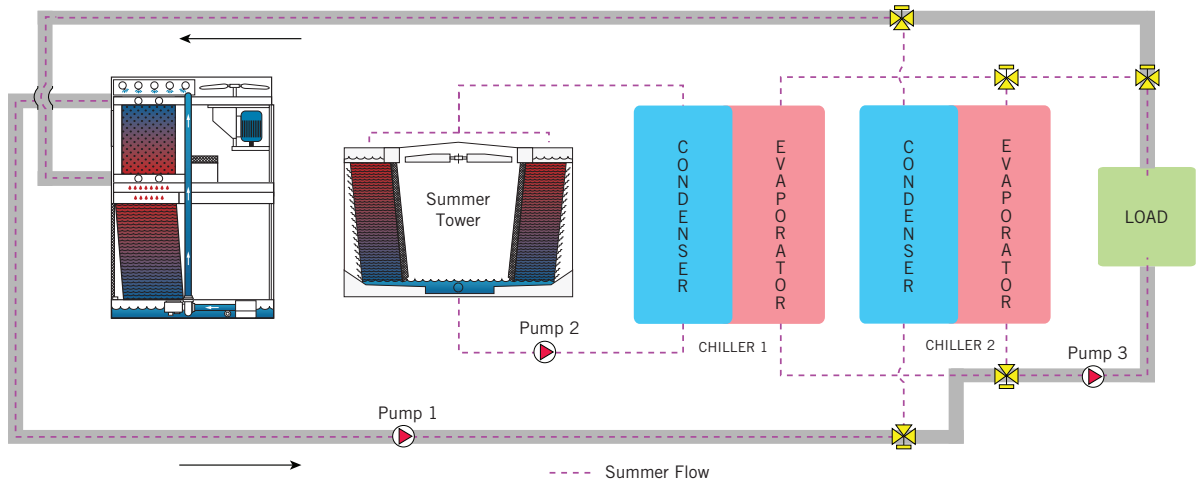

Figure 3b. Variation 2 - Closed Circuit Cooling Tower Free Cooling System with a Summer Cooling Tower for Multiple Chillers

- Variation 3 - Closed Circuit Cooling Tower System with a Summer Cooling Tower and Load Shaving (Figure 3c):**
 The closed circuit cooling tower is sized for the free cooling load and also is used in series with the chiller to reduce or shave the chiller load. An open cooling tower is sized and exclusively used for the condenser load, and it is not winterized. The closed circuit cooling tower begins to shave the load at a predetermined wet-bulb temperature by handling a portion of the chilled water load. As the wet-bulb temperature drops, the closed circuit cooling tower handles an increasing share of the load until the compressor finally can be turned off.

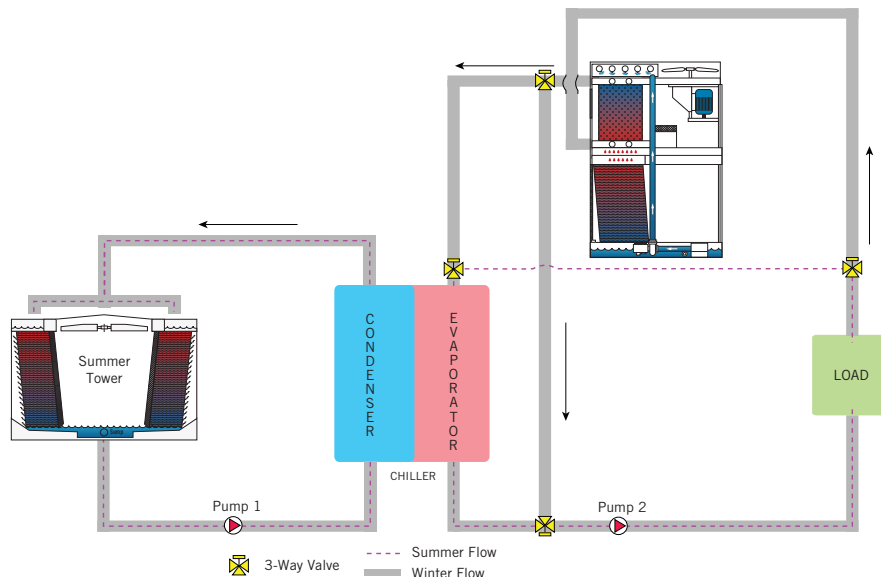

Figure 3c. Variation 3 - Closed Circuit Cooling Tower Free Cooling System with a Summer Cooling Tower and Load Shaving

Minimizing Energy Costs with Free Cooling

3. Refrigerant Migration (Figure 4):

In this system, valves are open between the condenser and evaporator of the chiller when the compressor is off. This allows free migration of refrigerant vapor from the evaporator to the compressor and of liquid refrigerant from the condenser to the evaporator. This system is limited to the phase change and requires the coldest possible water from the open tower or closed circuit cooling tower.

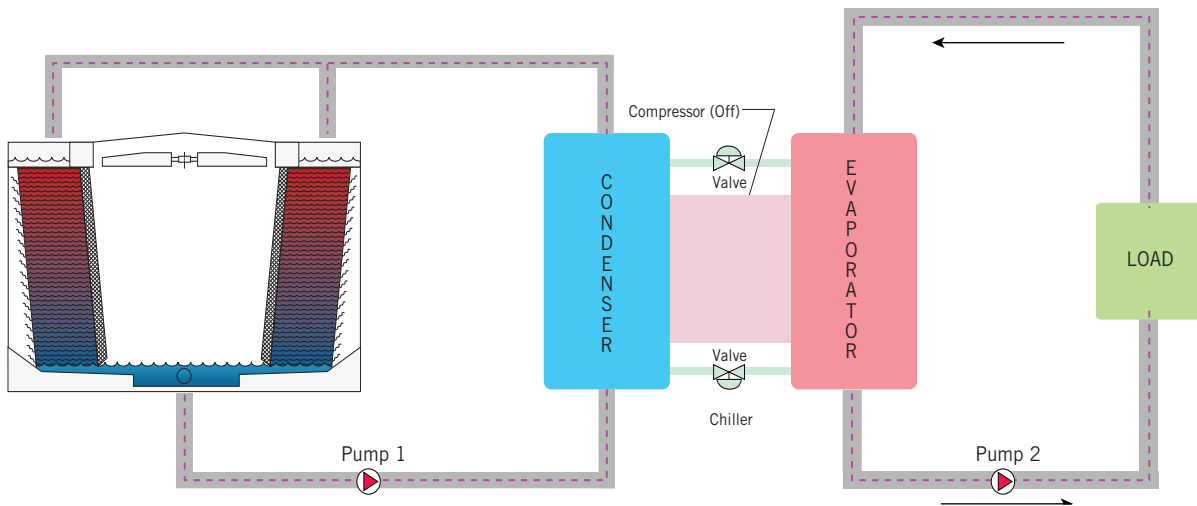

Figure 4. Refrigerant Migration Free Cooling System

Cooling load, climate, duty cycle, available space, operator skill, water and air quality, power and investment costs, maintenance, and other factors must be considered for the best system to be selected. Please contact your local BAC Representative for assistance with your system selection and sizing.

> Equipment Application

The common element in all free cooling systems is the cooling tower, which can reliably produce cold water at low ambient temperatures. While most evaporative cooling equipment can operate successfully in cold weather when the leaving water temperature is high (around 85°F/29.4°C), operation at low water temperatures of 45°F (7.2°C) to 50°F (10°C) in subfreezing weather is more difficult for cooling towers. Proper winterization of the unit is critical to prevent ice formation, which may affect free cooling operation or damage the unit. For winterization guidelines and alternatives, consult your local BAC Representative.

The reliability of any unit at low temperature operation depends on the following criteria:

- Layout
- Capacity control
- Freeze protection
- Routine maintenance program

Layout

The primary consideration in locating cooling towers for cold weather operation involves recirculation. Recirculation is when warm discharge air from a unit is reintroduced into air intakes. Recirculation during warm weather means some loss in tower capacity, which sometimes can be tolerated or even allowed for in the selection process. During cold weather, recirculation of this warm moist air can cause icing of the air inlets, which eventually can restrict airflow into the unit and damage the unit.

If units are selected/located in accordance with the manufacturer's guidelines, they can offer significant energy savings during cold weather while still meeting the needs of the overall system.

Capacity Control

Performance is a function of many variables, including airflow rate, temperature difference between air and water, and heat transfer surface area. An increase in any of these variables will increase the heat transfer rate and can possibly lead to cooling some of the water to the freezing point. The closer the leaving water temperature is to approaching freezing point, the greater the concern for icing. Therefore, the recommended minimum leaving fluid temperature is 42°F (5.6°C) for cooling towers and 45°F (7.2°C) for closed circuit cooling towers.

There are three operational methods that can balance a system's required cooling while limiting ice formation:

- Temperature settings
- Fan control
- Water flow control in open cooling towers

Combinations of controls depend on expected climatic extremes and variations in heat load.

Temperature Settings: When operating at subfreezing temperatures, an evaporative cooling unit produces leaving water temperatures appreciably below winter design temperature. While this may be acceptable to the system served, it tends to promote icing and should be avoided.

Higher leaving water temperatures improve ice control capabilities because more heat must be removed from water before ice will form. Therefore it is recommended that during subfreezing temperatures, a tower be operated at the highest possible leaving water temperature consistent with efficient system performance.

Fan Control: When ambient temperatures fall below freezing, the leaving water temperature falls below the winter design temperature. Full airflow through all cells is not required. Fan speeds can be reduced with the use of variable frequency drives, pony motor systems, or two speed motors, or by cycling off fans in some cells. Varying fan speed provides the most common and direct form of capacity control.

Water Flow Control in Open Cooling Towers: Water flow rate is an important consideration when operating in subfreezing temperatures. There are two flow conditions that must be avoided under these conditions: excessive flow and minimal flow.

If actual water flow is appreciably greater than design water flow, the water distribution basins may overflow. This splash out/overflow can cause ice buildup on the exterior of a unit, a roof, or the supporting structure.



Minimizing Energy Costs with Free Cooling

A less obvious, but potentially greater problem, is that of flow rates below the minimum water distribution system design level, because this may cause water starvation within certain areas of the fill. Such areas are susceptible to icing, which easily can go unnoticed until a tower is damaged. Low flow conditions usually are encountered when pumps are taken out of service because of reduced plant load or when automatic bypass systems are used to maintain design water temperatures. When such conditions are combined with below freezing ambient temperatures, cells must be taken out of service so that the load is distributed over as few cells as practical. This means the complete shutoff of water flow to a cell, not just fan control. When cells are taken out of service, always maintain operation of the tower furthest downstream to prevent freezing at the end of the distribution header pipe.

A bypass around the tower is desirable for tower start-up and shutdown during subfreezing temperatures, but great care must be taken when employing automatic bypass valves for capacity control. Automatic bypasses can be useful in maintaining high leaving water temperature and should be considered on jobs on which wide variations in load are anticipated. However, the control sequence is critical. Under subfreezing conditions, valves should not bypass more than 20% of the design water flow when fans are running or more than 50% of design water flow when fans are off. Units used in free cooling applications should have full bypass only (i.e., no system fluid should flow over the heat transfer surface) as a final step of control after fans are cycled off.

Freeze Protection

Basin Water Protection: All units operating at subfreezing temperature, except those located indoors in a heated space, must be equipped to prevent the basin water from freezing when the unit is idle. Common forms of protection include remote sumps and electric heaters.

Reverse Fan Operation (Induced Draft Crossflow Axial Fan Cooling Towers): In extreme climates or on free cooling applications, regardless of safeguards, ice may form on the louvers and/or fill of a cooling tower. In this case, with a heat load on the tower, the fan is operated in reverse to remove ice that has built up on the air inlet louvers or fill during normal operation. By reversing the airflow through the tower, heated air is supplied to the face of the fill and air inlet louvers, providing better ice removal capabilities than can be obtained by fan control alone.

Under severe operating conditions (below 0°F/-17.8°C ambient), the suggested procedure is to operate a fan in reverse for no more than 30 minutes every two or three hours or as needed. The actual frequency of reverse fan operation can be determined only by continued observation of the installation under varying operating conditions.

Although reverse fan operation can be automatic, manual operation with frequent inspection of the towers is preferred. In either case, a time delay of at least 40 seconds between forward and reverse must be incorporated into the controls. Automatic systems should include a provision for manual reversal of fans.

Fans should not be operated in reverse for extended periods because of the risk of fan failure and personal injury from ice formation on fan blades, fan stacks, and eliminators. Therefore, reverse operation should be limited and monitored.

Fans, drives, and motors furnished on cooling towers should be designed to operate in reverse without creating mechanical or electrical overloads. Also, it is necessary that cooling towers operated in subfreezing weather be equipped with fan vibration cutout switches as a safety precaution. This accessory is mandatory on units that will use reverse fan operation for ice control.

Start-up and Shutdown: The most critical periods of operation at subfreezing temperatures are tower start-up and shutdown, because the heat input is usually minimal at these times. It is recommended that systems be installed with a full flow water bypass so water can be circulated through the system without going over the cooling tower. On start-up the bypass is used until the temperature of water entering the tower rises to within 5°F (2.8°C) of the maximum tolerable temperature for the system. Once this level is reached, the bypass is closed and the full water flow is directed over the tower while the fans remain off.

If a provision for bypass is not included in the system design, circulating pumps should not be started until the last possible moment consistent with plant operation. Tower fans should not be turned on until the temperature of the circulating water leaving the tower reaches approximately 5°F (2.8°C) below the maximum tolerable temperature for the system. At this point, fans can be cycled on low speed. On start-up, it is important that heat load be increased as rapidly as possible until the minimum recommended leaving water temperature is achieved.

The recommended shutdown procedure essentially is the reverse of the start-up procedure. As load drops, fans are cycled simultaneously to maintain the recommended tower leaving water temperature. Once all fans are off, a bypass is employed to go to full bypass without water passing over the tower at the earliest possible moment. In systems without bypass provision, tower pumps should be stopped as soon as temperatures in the tower drop below the recommended minimum or as soon as possible thereafter consistent with the cooling needs of the system.

In subfreezing weather, under no circumstances should a cooling tower operate for extended periods without a heat load or flow.

Freeze Protection in Closed Circuit Cooling Towers: At below freezing ambient temperatures, heat loss from a closed circuit cooling tower located outdoors can be substantial, even without flow through the unit and operating fans. Without a heat load on the circulating fluid, coil freezing can occur, even with full fluid flow. The use of an inhibited antifreeze solution in the coils is recommended. Two factors need to be addressed during design: (1) the increase in required pump head because of the increased viscosity of the antifreeze solution and (2) the minimal decrease in capacity. Pump head requirements and capacity reductions depend on the type of antifreeze and the concentration of the solution. Contact your local BAC Representative for selection assistance.

Theoretically, damage from freezing is prevented because antifreeze solution forms a slush solution as it begins to freeze. Most of the fluid expansion takes place during the slush forming stage. If there is a tank to accommodate the expansion, the equipment will be protected from the high pressure in the system piping.

If the use of an antifreeze solution is not practical, the system must be designed to meet both minimum flow and leaving fluid temperature requirements.

Routine Maintenance Program

Maintenance is particularly important for cooling towers operated in subfreezing weather to protect against problems that can cause icing.

First, visual inspections of a tower must be performed on a regular and frequent basis to:

- Ensure that the method of ice control is effective.
- Ensure that all controls are set properly and functioning normally.
- Discover icing conditions before the unit or supports are damaged or system performance is impaired.



Minimizing Energy Costs with Free Cooling

Additionally, a regular preventative maintenance schedule must be established and carried out, despite adverse weather conditions. Items covered should include:

- Regular lubrication of bearings with the proper type of grease as indicated in the Operation and Maintenance manual.
- Regular cleaning of strainer screens to prevent excessively high water levels in the cold water basin.
- Regular checking and adjustment of the makeup water float valve to ensure correct water levels in the cold water basin.

> Example Payback Period

To better understand how much, in terms of dollars, free cooling can actually save in the long run through energy conservation, the example below shows the payback period using free cooling as opposed to a standard system.

Design Conditions

1. Summer Condenser Load: 1155 gpm cooled at 95/85/77° EWB.
2. Winter Cooling Tower Load: 1155 gpm 44.4/42/28°F EWB.
3. Winter Chilling Load: 927 gpm 49.7 to 47.2°F
4. Ambient Wet-bulb Switchpoint over 28°F, Annual Operating hours at or below switch point = 2097
5. Energy Cost = 0.12 \$/kwh. Motor Power Factor = 0.90 Motor Efficiency = 0.95

System Component	Selection Conditions	Model Number	Purchase	Operating HP	
				Standard System	Free Cooling
Chiller		400 Ton Centrifugal		155	
Cooling Tower		3412C			
Heat Exchanger		Plate and Frame	36,600	25	25
Chilled Water Pump		End suction			
Condenser Water Pump				15	15
Additional Piping			5200	20	20
Total			41,800	215 (B)	60 (C)

Cost Calculations

Additional First Cost = \$41,800

Annual Operating Cost Savings = Operating HP at Std – Operating HP at Free Cooling * (PF * Eff) * Energy Cost * Operating Hours.
 = (215-60) * (0.90*0.95) * 0.12 * 2097
 = \$33,348 Annual Operating Cost Savings

$$\text{Payback} = \frac{\text{Additional First Cost}}{\text{Annual Operating Cost Savings}} = \frac{\$41,800}{\$33,348} = 1.25 \text{ years}$$

> Summary

Free cooling is a straight forward concept that can be applied to new and existing water cooled projects with relative ease. The cooling provided, of course, is not completely “free” because the tower, chilled water pumps, and tower fans still must be operated. Nonetheless, it allows cost conscious building or process owners and operators to take advantage of naturally occurring climate conditions to save system operating costs. The concept has been applied successfully for many years to the delight of many system owners. Free cooling can be used to save energy whenever outside wet bulb temperature drops below the required chilled water set point and can save enough compressor electric power to pay for the cost. Please contact your local BAC Representative for assistance with system selection and sizing.